

TYPICAL HOOKUP

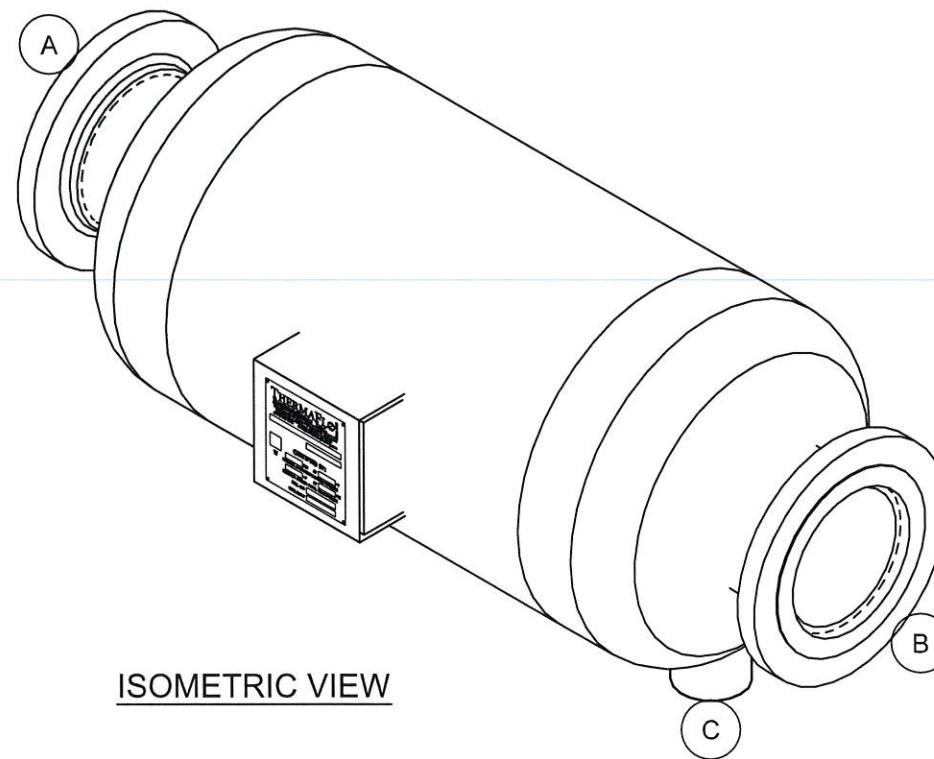

ISOMETRIC VIEW

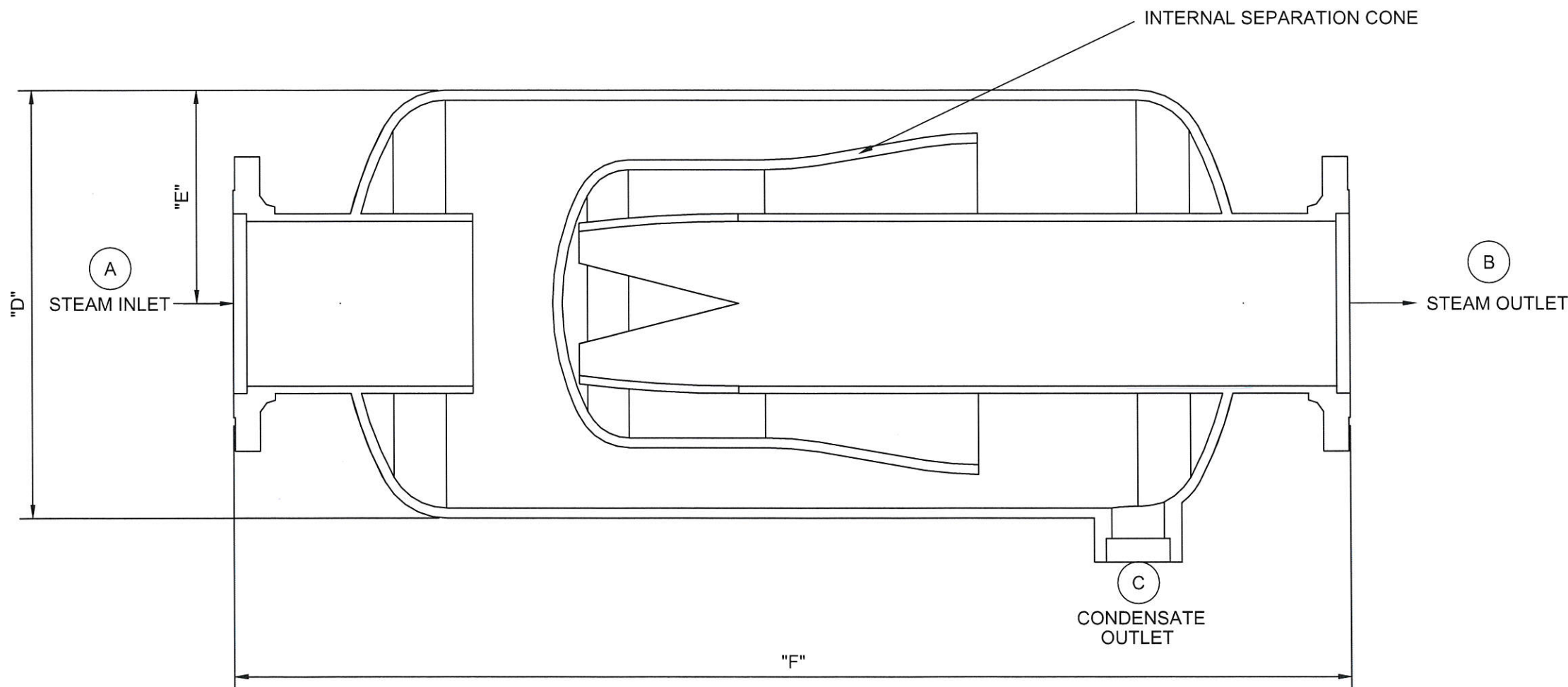

INTERIOR CUT-AWAY VIEW

**BODY CONSTRUCTION:**

CARBON STEEL, ASME CODE STAMPED (STANDARD)  
 STAINLESS STEEL, ASME CODE STAMPED (OPTIONAL)

**DESCRIPTION:**

THE HSS STEAM SEPARATORS ARE USED IN STEAM SUPPLY LINES TO REMOVE CONDENSATE, CARRYOVER AND ENTRAINED MOISTURE ENHANCING HEAT TRANSFER AND ELIMINATING WIRE DRAWING OF CONTROL VALVE SEATS WHILE PRODUCING DRY QUALITY STEAM.

**CONDITIONS OF SERVICE:**

MAX OPERATING PRESSURE: 150 PSIG

MAX OPERATING TEMPERATURE: 400°F

**MAXIMUM FLOW RATE CAPACITY FOR HIGHEST EFFICIENCY IN LBS/HR**

INLET PRESSURE	2"	3"	4"	6"	8"
15 PSIG	1000	2500	3150	8100	9200
30 PSIG	1650	3300	4190	12,500	15,900
50 PSIG	1850	4100	7500	15,500	21,000
75 PSIG	2600	4900	8400	20,000	30,000
100 PSIG	3100	6000	13,900	26,000	38,500
125 PSIG	3400	7100	17,500	36,000	43,700
150 PSIG	4500	11,000	19,000	40,000	50,000

**DIMENSION CHART**

	2"	3"	4"	6"	8"
"A"	150#	150#	150#	150#	150#
"B"	150#	150#	150#	150#	150#
"C"	3/4"	1-1/2"	2"	2"	2"
"D"	8"	12"	12"	14"	16"
"E"	4"	6"	6"	7"	8"
"F"	26"	32"	32"	36"	40"

**NOTE:**

INSTALL FLOAT AND THERMOSTATIC STEAM TRAP SIZED FOR 5% OF MAX FLOW AT THE CONDENSATE OUTLET. EXAMPLE: 4" @ 100PSIG=13,900 LBS/HR X 590 = 695 LBS/HR (SIZE 3/4" THERMAFLO FTC-125) 100PSIG DIFFERENTIAL PRESSURE

1	RSP	MISC CHGS
#	DATE	REVISION

**THERMAFLO** ENGINEERING INC. Since 1986

Manufacturers Of Steam Fired Specialty Equipment  
 12249 Nations Ford Road, Pineville NC 28134  
 (704) 940-1228 www.thermafloengineering.com

**DESCRIPTION:**

HSS-STEAM SEPARATOR - SALES

CUSTOMER:	TECH INFORMATION SHEET	JOB #	STANDARD	QTY.	DATE:
SCALE:	DRAWN:	PO #	FILE:	REV. #	PAGE:
NTS	RSP	-	SAME	-	-